

BASS SLAMMER™

BASSslammer.com

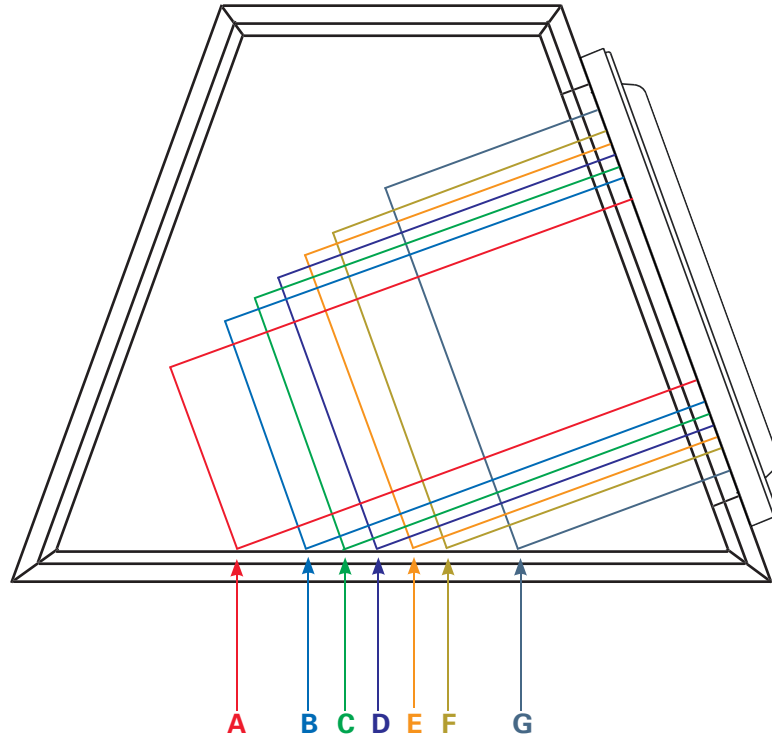

A.	Max. Mounting Depth: Max. Motor Diameter:	10-1/4" (260.35mm) 4" (101.6mm)	E.	Max. Mounting Depth: Max. Motor Diameter:	6-13/16" (173.04mm) 6-1/2" (165.1mm)
B.	Max. Mounting Depth: Max. Motor Diameter:	8-7/8" (225.43mm) 5" (127.0mm)	F.	Max. Mounting Depth: Max. Motor Diameter:	6-1/8" (155.58mm) 7" (177.8mm)
C.	Max. Mounting Depth: Max. Motor Diameter:	8-3/16" (207.96mm) 5-1/2" (139.7mm)	G.	Max. Mounting Depth: Max. Motor Diameter:	4-3/4" (120.65mm) 8" (203.2mm)
D.	Max. Mounting Depth: Max. Motor Diameter:	7-1/2" (190.5 mm) 6" (152.4mm)			

Model Number:	W110.65S
Description:	Single 10" Unloaded Sealed Trapezoidal Enclosure
Exterior Dimensions:	12-1/4" x 13" x 16" x 7-1/8" (HxWxD BASExD TOP)
Tuning Frequency:	N/A
Internal Volume:	.65 cu ft
Construction:	5/8" Particle Board

