

BASS SLAMMER™

CF10

Enclosure Volume: .6 Cubic Foot, Sealed

READ ALL DIRECTIONS CAREFULLY BEFORE BEGINNING

MOUNTING LOCATION: The enclosure mounts on the driver's side in rear hatch on Camaro, Firebird, Camaro RS, Z28 and Trans-Am.

TOOLS FOR INSTALLATION:

Powered Screwdriver

#2 Phillips Head Bit

7/16" Nut Driver

INSTALLATION: Follow the steps below

1. Remove the trim panel on the driver side of vehicle by pulling up on panel as shown below.

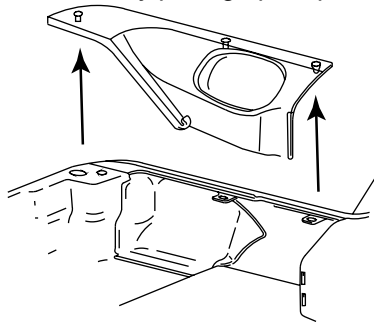

2. Enclosure mounts firing towards the center of the vehicle under the trim piece on the driver's side of vehicle.

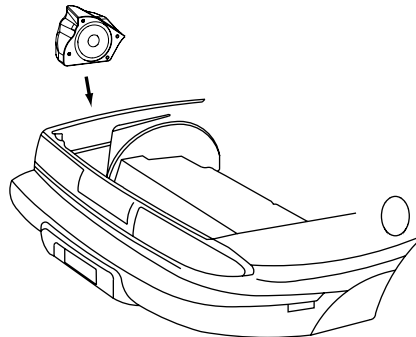

3. Make speaker connections to the enclosure from the amplifier, loosen terminal knobs (a 13mm nut driver can be used). Connect speaker wires from amplifier to enclosure, positive to red terminal knob and negative to black terminal knob.
4. Install the enclosure into vehicle as shown below with screws provided.

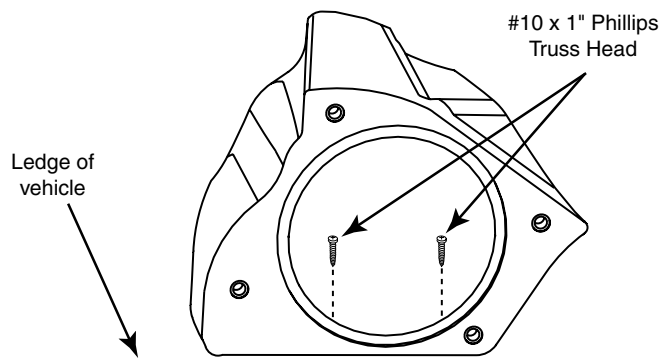

5. Place gasket provided around woofer hole cutout. Connect black wire to the negative side of woofer and red to the positive side. Using screws provided install woofer into enclosure, making sure not to overtighten screws to avoid stripping.
6. Install grill, insert pegs provided into holes on the back of grill using a 7/16" nut driver to push pegs into the holes. Align the pegs on grill with the receptacles on enclosure and snap into place.
7. Re-install trim panel in rear of vehicle on the driver side.

FACTORY SPEAKER WIRE COLORS

The rear speaker wires are located in the door pillars behind the front seats. Colors are right side dark blue (positive), light blue (negative), and left side brown (positive), yellow (negative).

Although every effort has been made to assure proper wiring color, Mitek is not responsible for any changes made by the vehicle manufacturer which sometime occur. If wiring colors do not match then physical verification is required. These instructions are guidelines only and in no way are intended to replace a professional installation. As always before screwing and drilling check to make sure you will not damage wires, hoses or cause damage to the vehicle.

Bose Sub System

Warning- You must have an adapter to convert from the Bose System to an aftermarket amplifier, we recommend acquiring one and following the directions provided with the adapter.

MAXIMUM ENCLOSURE MOUNTING SPECIFICATIONS

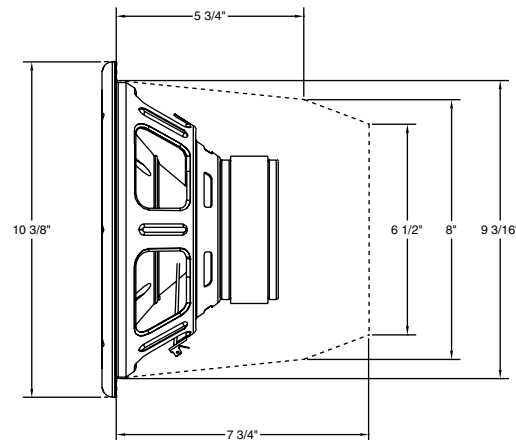

**MAXIMIZE YOUR SYSTEM'S
PERFORMANCE**

streetwires.com

STREETWIRES®